

Contents

Important User Information	2	Before Assembly	10
Safety Precautions	3	Assembly	11
Required Tools	3	Safety Check	26
Unpacking	4	Moving and Storage	27
Parts List	5	Connecting Riser Units	28
Hardware Pack - Casters	5	Reversed Riser Assembly	29
Hardware Pack - Plastic Parts	5		
Hardware Pack - Fasteners	6		
Step Components	7		
Chassis Components	8		
Backrail Components	9		



Visit the Signature Choral Risers web page at wengercorp.com for more information.

Note: Please read and understand these instructions before proceeding.
Note: If you need additional information, contact Wenger Corporation using the information below.

Important User Information

General

Copyright © 2024 by Wenger Corporation

All rights reserved. No part of the contents of this manual may be reproduced, copied, or transmitted in any form or by any means including graphic, electronic, or mechanical methods or photocopying, recording, or information storage and retrieval systems without the written permission of the publisher, unless it is for the purchaser's personal use.

Printed and bound in the United States of America.

The information in this manual is subject to change without notice and does not represent a commitment on the part of Wenger Corporation. Wenger Corporation does not assume any responsibility for any errors that may appear in these instructions.

In no event will Wenger Corporation be liable for technical or editorial omissions made herein, nor for direct, indirect, special, incidental, or consequential damages resulting from the use or defect of these instructions. The manufacturer reserves the right to change this product at any time.

The information in this document is not intended to cover all possible conditions and situations that might occur. The end user must exercise caution and common sense when assembling or installing Wenger Corporation products. If any questions or problems arise, call the Wenger Corporation at (800) 4WENGER (493-6437) or +1-507-455-4100 worldwide.

Manufacturer

The Signature® Choral Riser 4-Step Model is manufactured by:

Wenger Corporation
555 Park Drive
Owatonna, MN 55060
(800) 4WENGER (493-6437) • +1 (507) 455-4100
wengercorp.com

Intended Use

- This product is designed to be an elevation step for vocal groups.
- This product is intended for indoor use in normal ambient temperature and humidity conditions – it must not be exposed to prolonged outside weather conditions.
- This product is intended to be assembled, installed and used only as described in these instructions.

Warranty

Warranty information is available at wengercorp.com.

Safety Precautions

Throughout this document you may find cautions and warnings which are defined as follows:

- **WARNING:** Failure to follow the instruction could result in serious injury or damage to property.
- **CAUTION:** Failure to follow the instruction could result in minor injury or damage to property.

Read all of these safety instructions before assembly or use.

⚠ CAUTION

Make sure anyone assembling, installing or using this product has read and understands these instructions.

⚠ CAUTION

Failure to comply with Warnings and Cautions in this document or on the equipment can result in damage to property or serious injury.

⚠ CAUTION

To help avoid damage and injury, two people are recommended for assembly.

Required Tools

- Drill or impact driver with 1/2" and 9/16" deep well sockets
- 1/2" and 9/16" Wrenches

Unpacking

CAUTION

Set up and use the riser only on flat, solid surfaces.



1. Read and understand the complete assembly procedure before beginning.
It is recommended to unpack and sort the items according to the order of assembly.
2. Remove all parts from the shipping cartons.
Each riser is shipped in two cartons:
 - one shorter carton containing the chassis.
 - one longer carton containing the back rail and steps.
3. Sort all accessories by order of assembly.
Use carpeting, a rug, or the cardboard carton to soften a hard floor and prevent scratching riser surfaces.
4. Risers should be assembled indoors, in a well-lighted space with a level floor.
Choose an area close to the performance space.
Make sure risers will fit through doors between the assembly area and the performance space.

Parts List

Hardware Pack - Casters

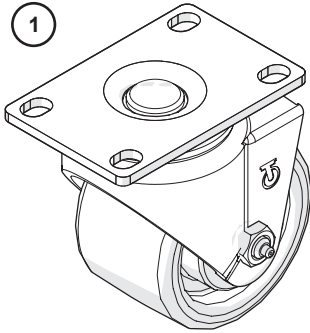

Swivel Caster

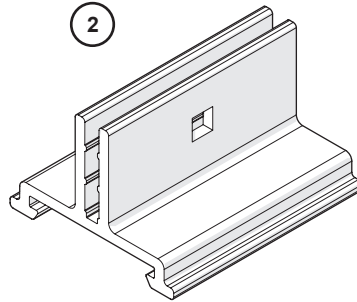

Caster Mount

Hardware Pack - Plastic Parts

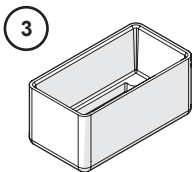

1" x 2" Cap

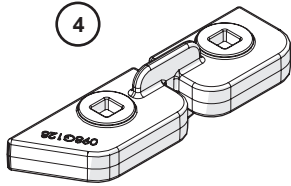

Front Bumper

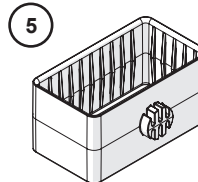

Snap-In Glide

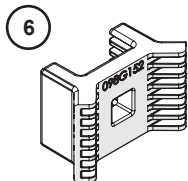

Backrail
Stop Block

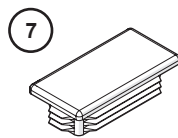

1" x 2" Plug

Parts List (continued)

Hardware Pack - Fasteners

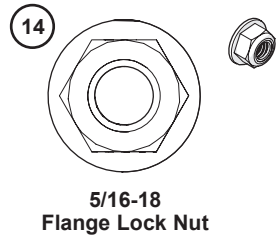
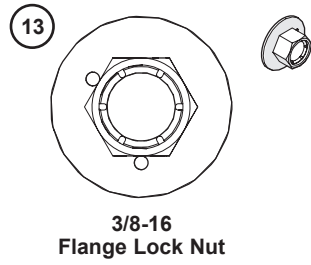
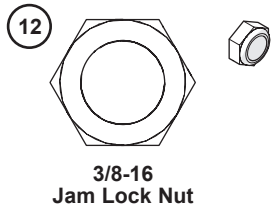
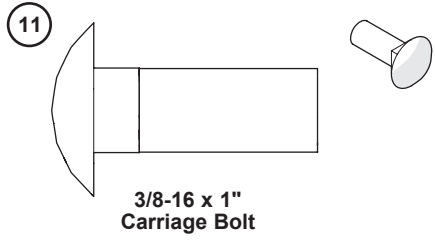
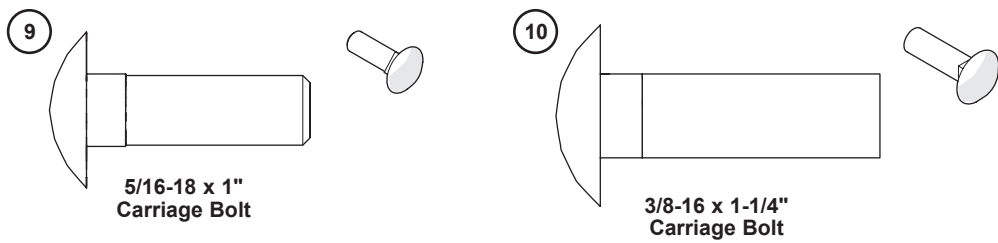
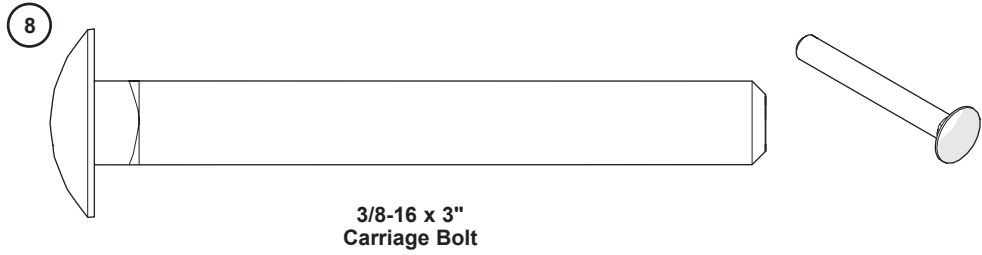

Parts List (continued)

Step Components

Item	Description	Item	Description
16	1st Step	11*	3/8-16 x 1" Carriage Bolt
17	2nd Step	13*	3/8-16 Flange Lock Nut
18	3rd Step	<i>*Included in Hardware Packs</i>	
19	4th Step		
20	Unit Connector Bracket		
21	1/4" Dia. Blind Rivet		
22	5/16-18 x 5/8" Capscrew		

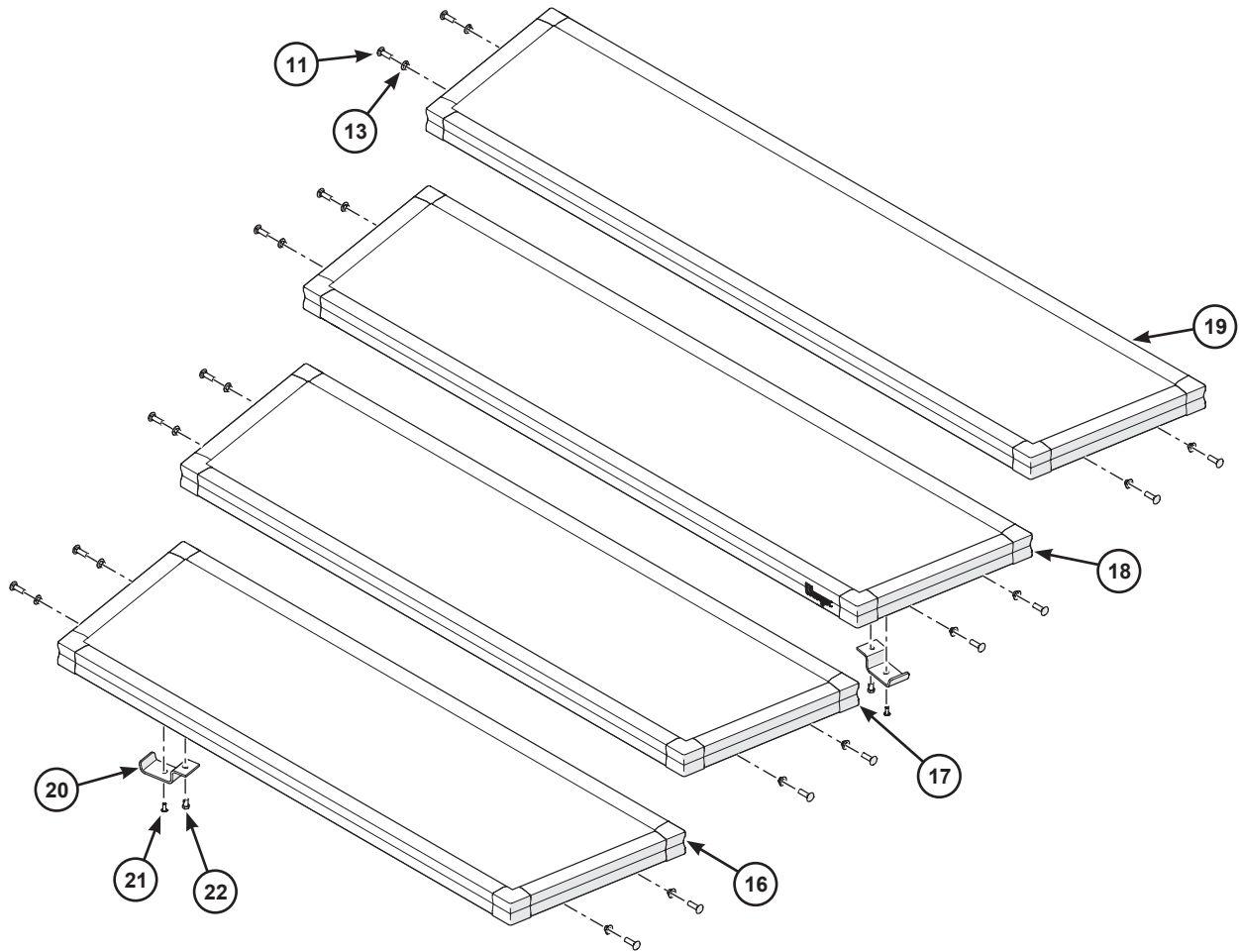

Parts List (continued)

Chassis Components

Item	Description	Item	Description
23	Frame Assembly, Left Side	1*	Swivel Caster
24	Frame Assembly, Right Side	2*	Caster Mount
25	Bottom Truss Pan	4*	Front Bumper
26	Top Truss Pan	5*	Snap-In Glide
27	Front Truss Weldment	9*	5/16-18 x 1" Carriage Bolt
28	Small Truss Pan	10*	3/8-16 x 1-1/4" Carriage Bolt
		11*	3/8-16 x 1" Carriage Bolt
		13*	3/8-16 Flange Lock Nut
		14*	5/16-18 Flange Lock Nut
*Included in Hardware Packs			

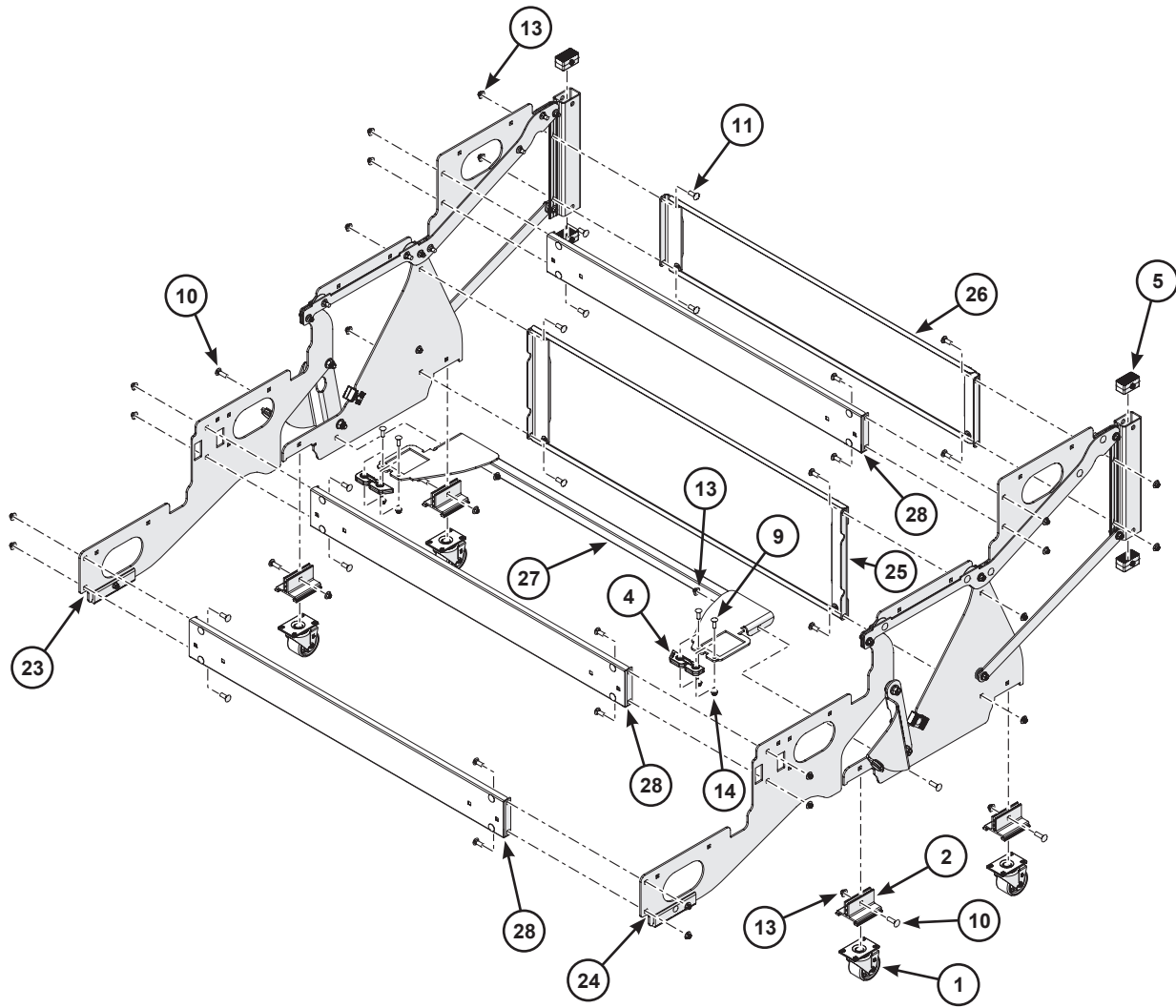

Parts List (continued)

Backrail Components

Item	Description	Item	Description
29	Backrail Upright Tube	3*	1" x 2" Cap
30	Backrail Horizontal Tube	6*	Backrail Stop Block
31	Backrail End Cap, 1-1/4" OD	7*	1" x 2" Plug
		8*	3/8-16 x 3" Carriage Bolt
		12*	3/8-16 Jam Lock Nut
		13*	3/8-16 Flange Lock Nut
*Included in Hardware Packs			

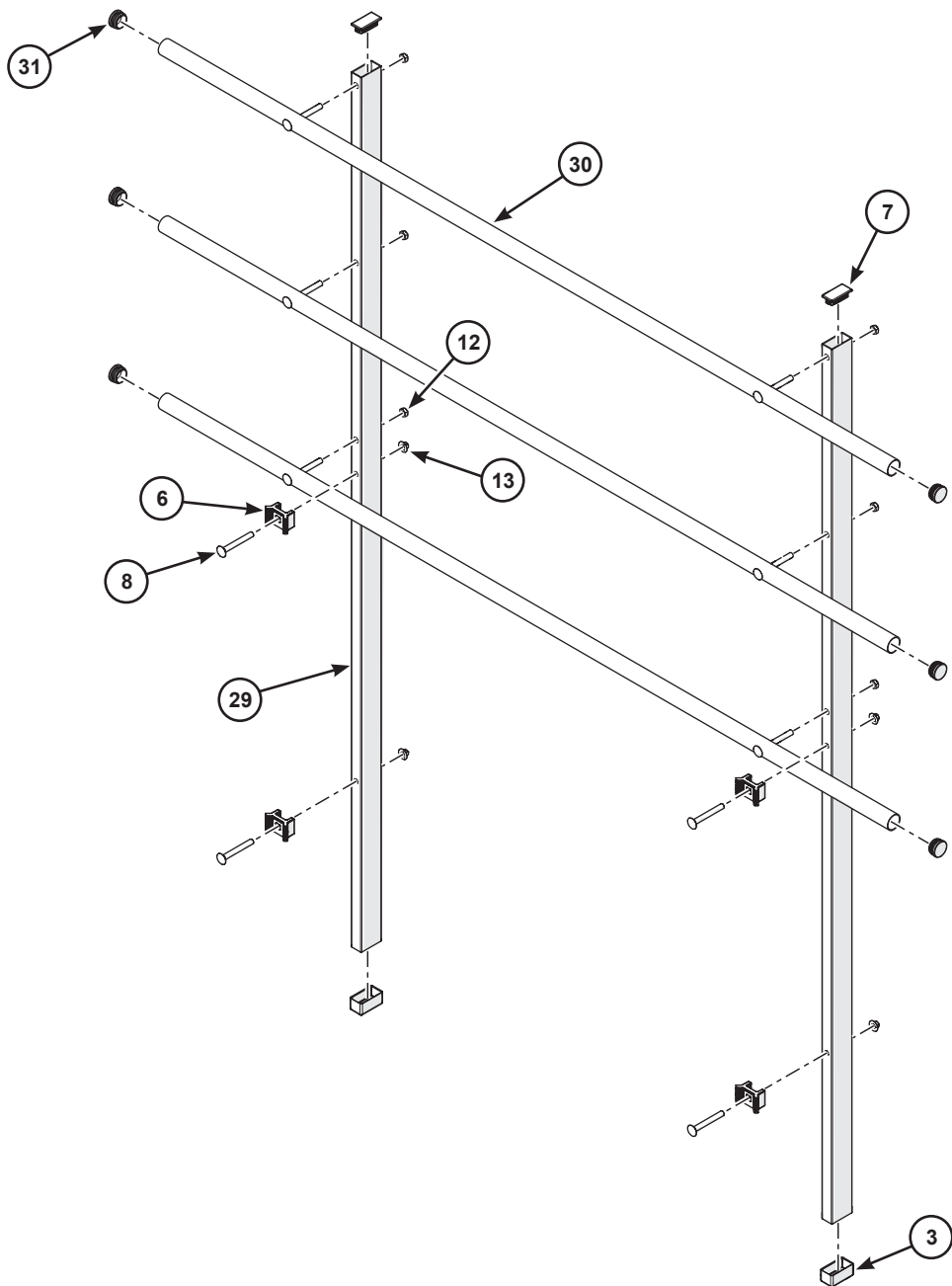

Before Assembly



The following assembly instructions show standard riser assembly.
Risers can be connected together for use in two different configurations.

In an arc configuration, all risers are assembled standard as shown in these instructions.

In a straight configuration, alternating riser sets must be assembled with the steps and backrail reversed. See "Reversed Riser Assembly" on page 29.

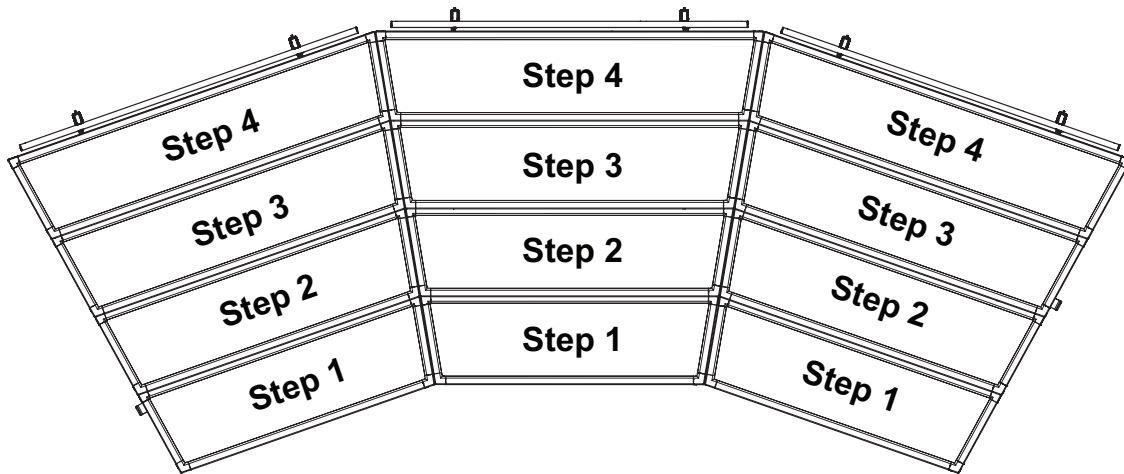

Arc Configuration
(Uses all Standard Assembly Risers)

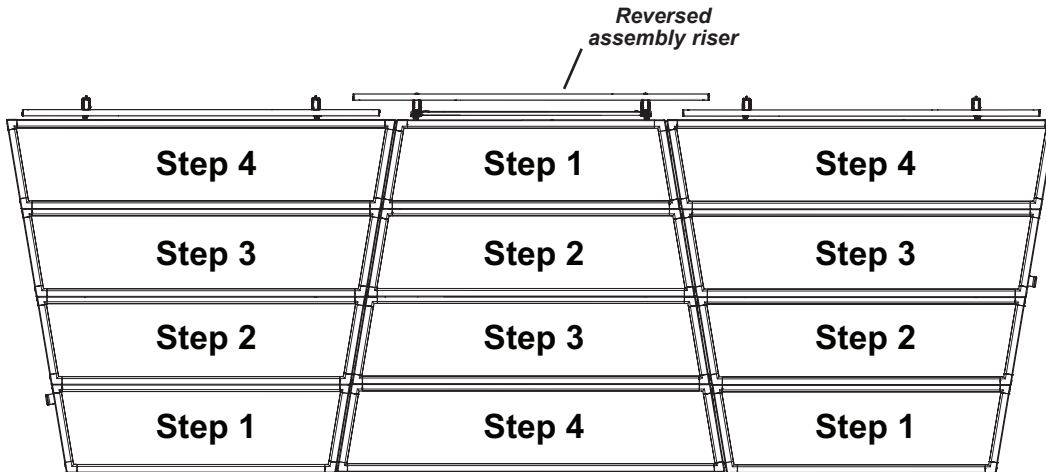

Straight Configuration
(Alternating Risers are Reversed Assembly)

Assembly

1. Attach the rear casters to the side frames.

For both side frames:

- a. Slide one swivel caster (1) into a caster mount (2).
- b. Attach the caster mount to the side frame assembly (23) (left side) and (24) (right side) using one 3/8-16 x 1-1/4" carriage bolt (10) and a 3/8-16 flange lock nut (13) in each.

Note the orientation of the side frame assemblies.

This step uses fasteners:

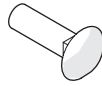

3/8-16 x 1-1/4"
Carriage Bolt ⑩



3/8-16
Flange Lock Nut ⑬

CAUTION

*Do not cut plastic bands until instructed to do so.
Damage or injury could occur.*

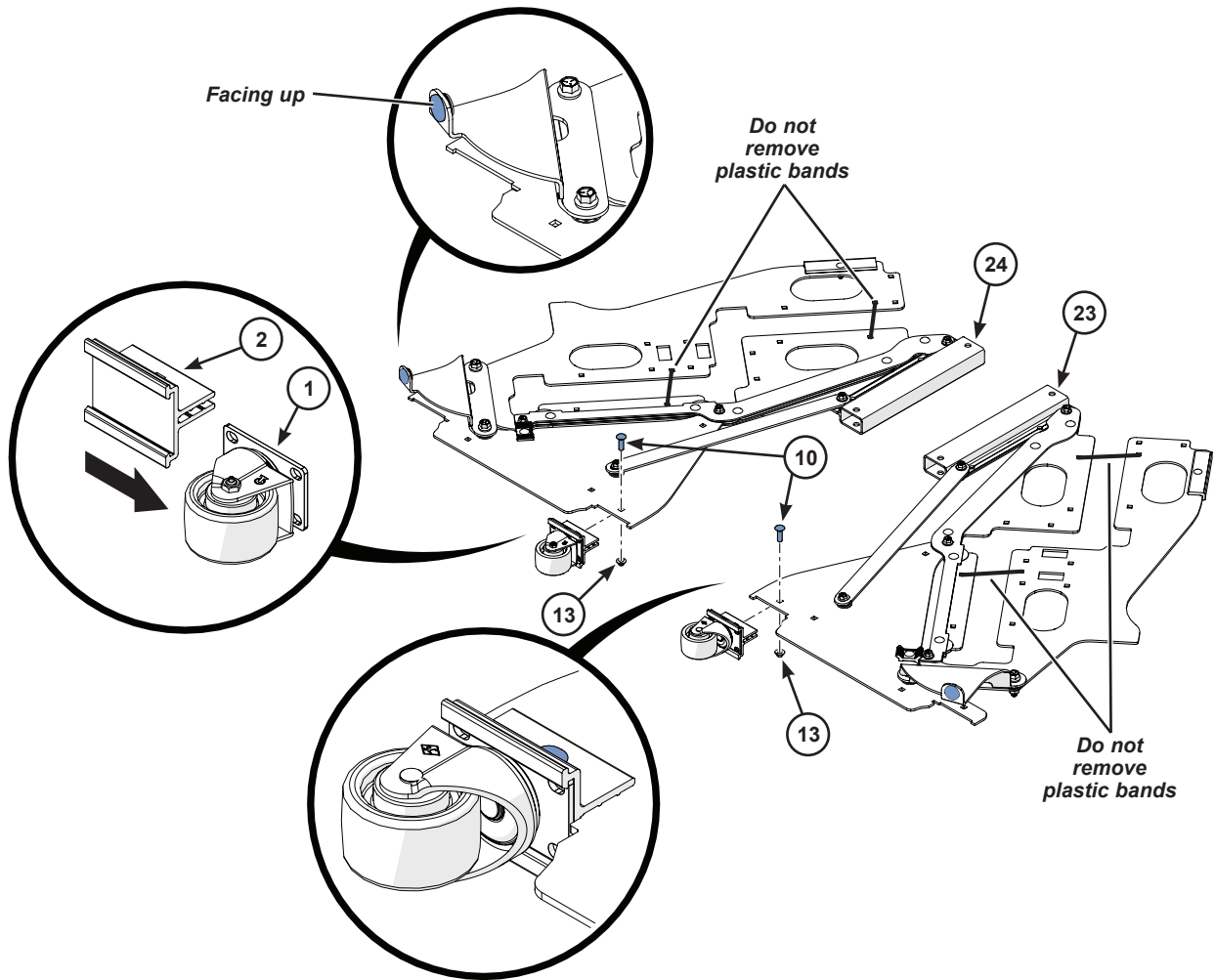

Assembly (continued)

2. Attach the bottom truss pan to the side frames.
 - a. Hold or brace the side frame assemblies upright.

Note the orientation of the side frame assemblies.

- b. Attach the bottom truss pan (25) using two 3/8-16 x 1" carriage bolts (11) and 3/8-16 flange lock nuts (13) on each side.

This step uses fasteners:



3/8-16 x 1"
Carriage Bolt (11)



3/8-16
Flange Lock Nut (13)

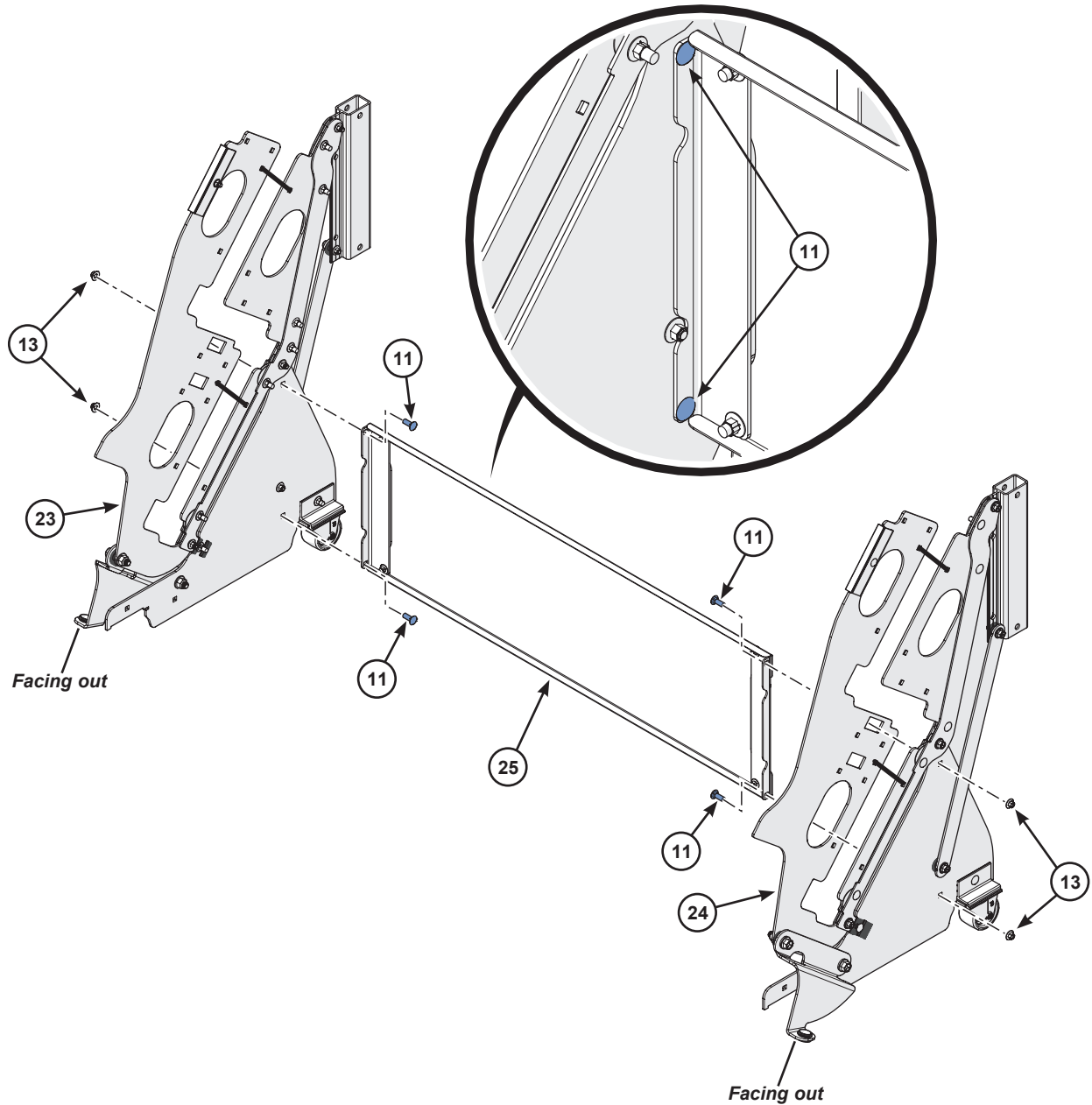

Assembly (continued)

3. Attach the top truss pan (26) to the side frames using two 3/8-16 x 1" carriage bolts (11) and 3/8-16 flange lock nuts (13) on each side.

This step uses fasteners:



3/8-16 x 1"
Carriage Bolt (11)



3/8-16
Flange Lock Nut (13)

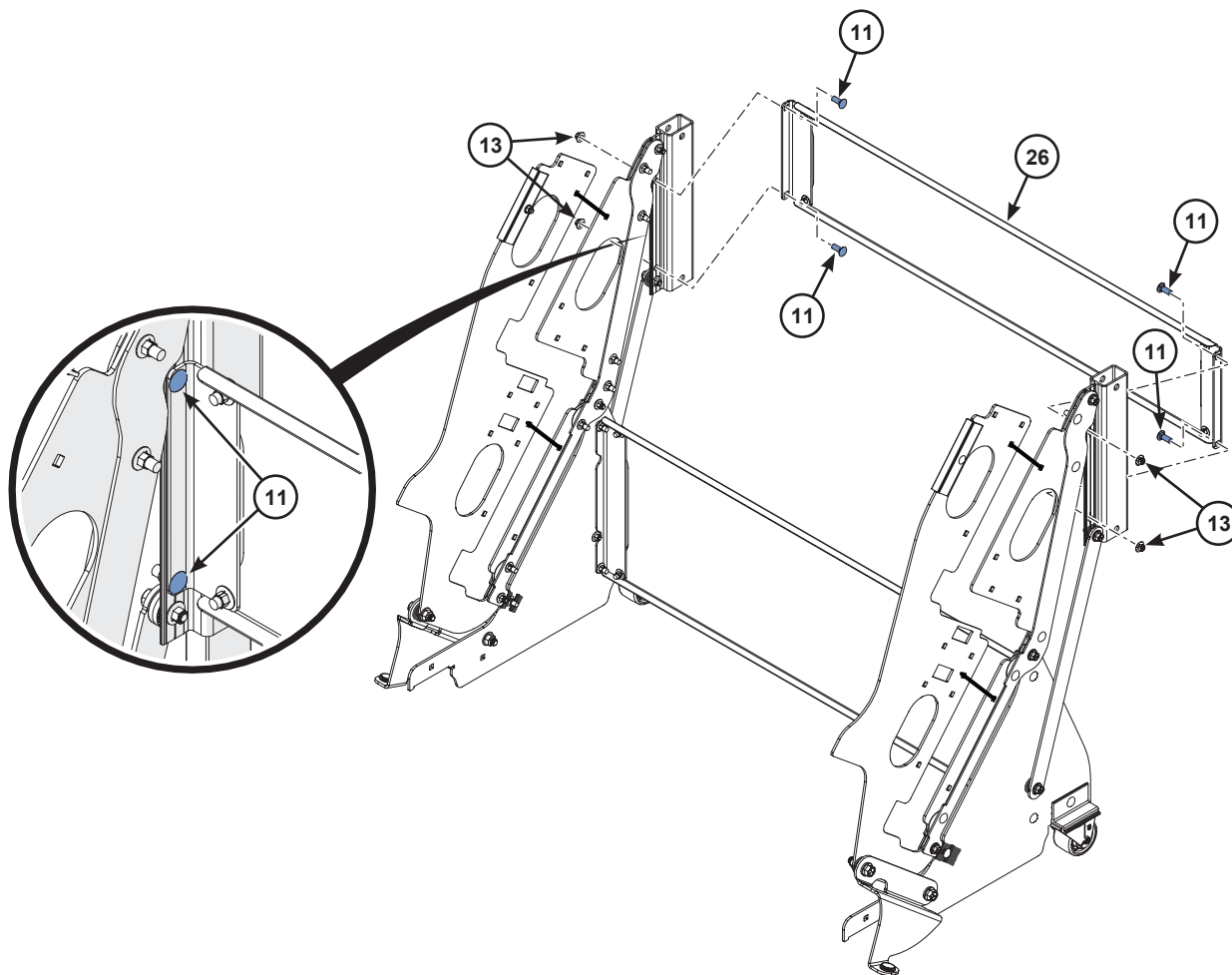

Assembly (continued)

4. Carefully tip the riser onto its back.
5. Attach the front truss weldment to the side frames.
 - a. Fit the front truss weldment (27) onto the side frames.
 - b. **Loosely** attach the front truss weldment (27) using two 3/8-16 x 1-1/4" carriage bolts (10) and 3/8-16 flange lock nuts (13).

This step uses fasteners:

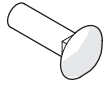

3/8-16 x 1-1/4"
Carriage Bolt (10)



3/8-16
Flange Lock Nut (13)

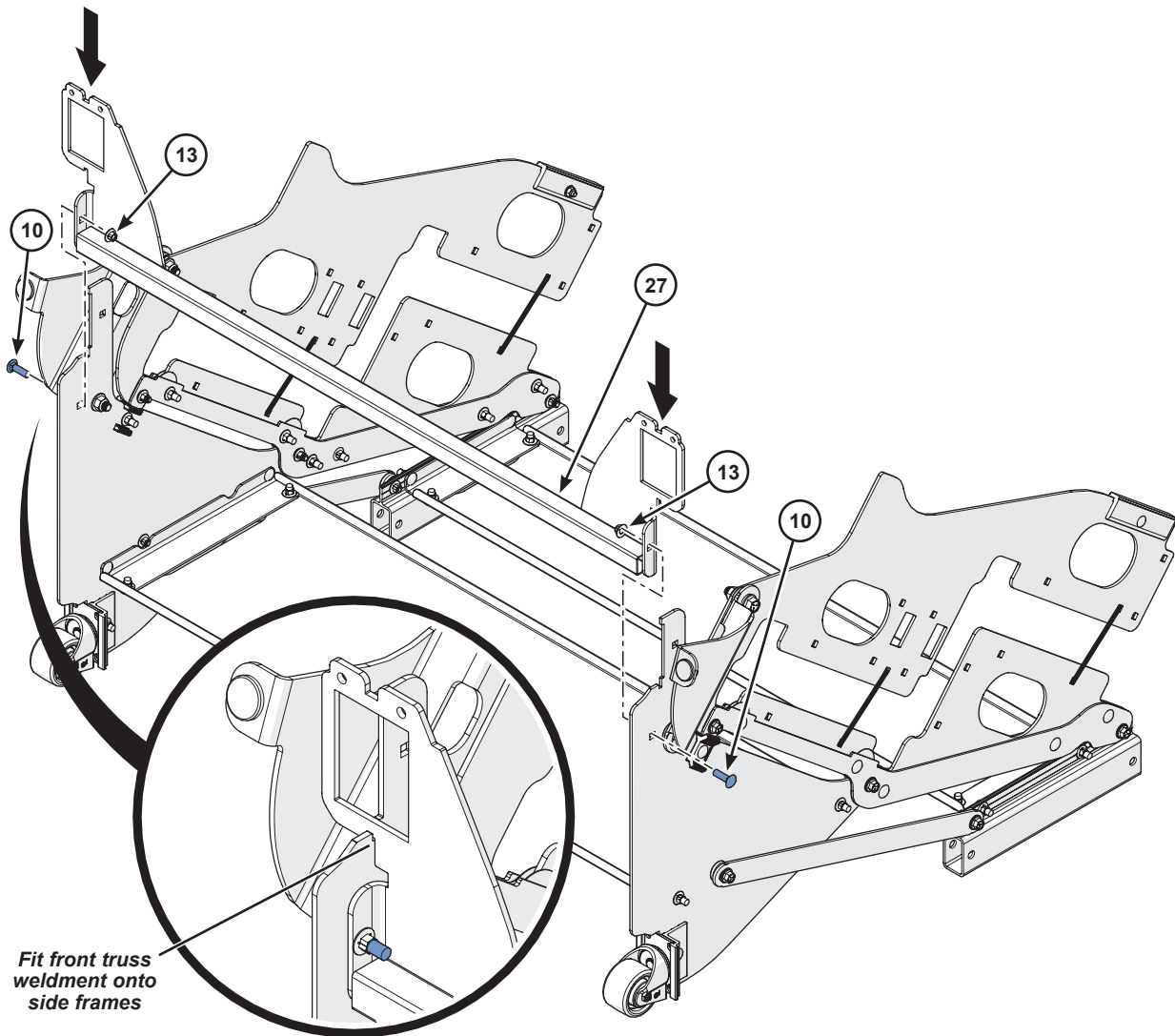

Fit front truss
weldment onto
side frames

Assembly (continued)

6. Attach the front casters to the side frames.
For both sides:
 - a. Slide one swivel caster (1) into a caster mount (2).
 - b. Attach the caster mount to the side frames using one 3/8-16 x 1-1/4" carriage bolt (10) and a 3/8-16 flange lock nut (13).
 - c. Tighten the front truss weldment fasteners on both sides from step 5b.

This step uses fasteners:

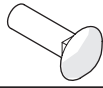

3/8-16 x 1-1/4"
Carriage Bolt (10)



3/8-16
Flange Lock Nut (13)

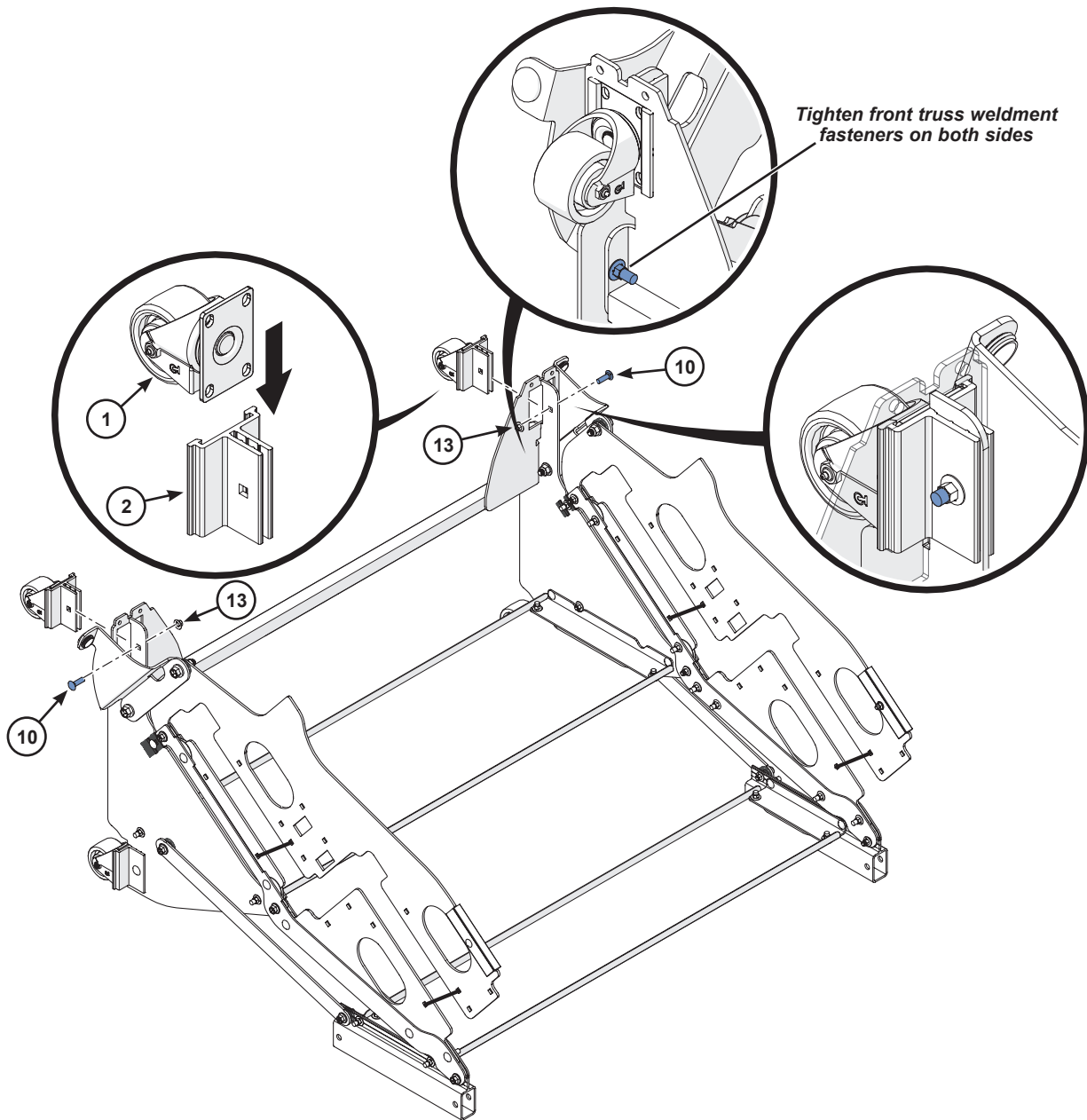

Assembly (continued)

7. Attach front bumpers (4) to both sides of the front truss weldment using two 5/16-18 x 1" carriage bolts (9) and 5/16-18 flange lock nuts (14) in each.

This step uses fasteners:



5/16-18 x 1"
Carriage Bolt (9)



5/16-18
Flange Lock Nut (14)

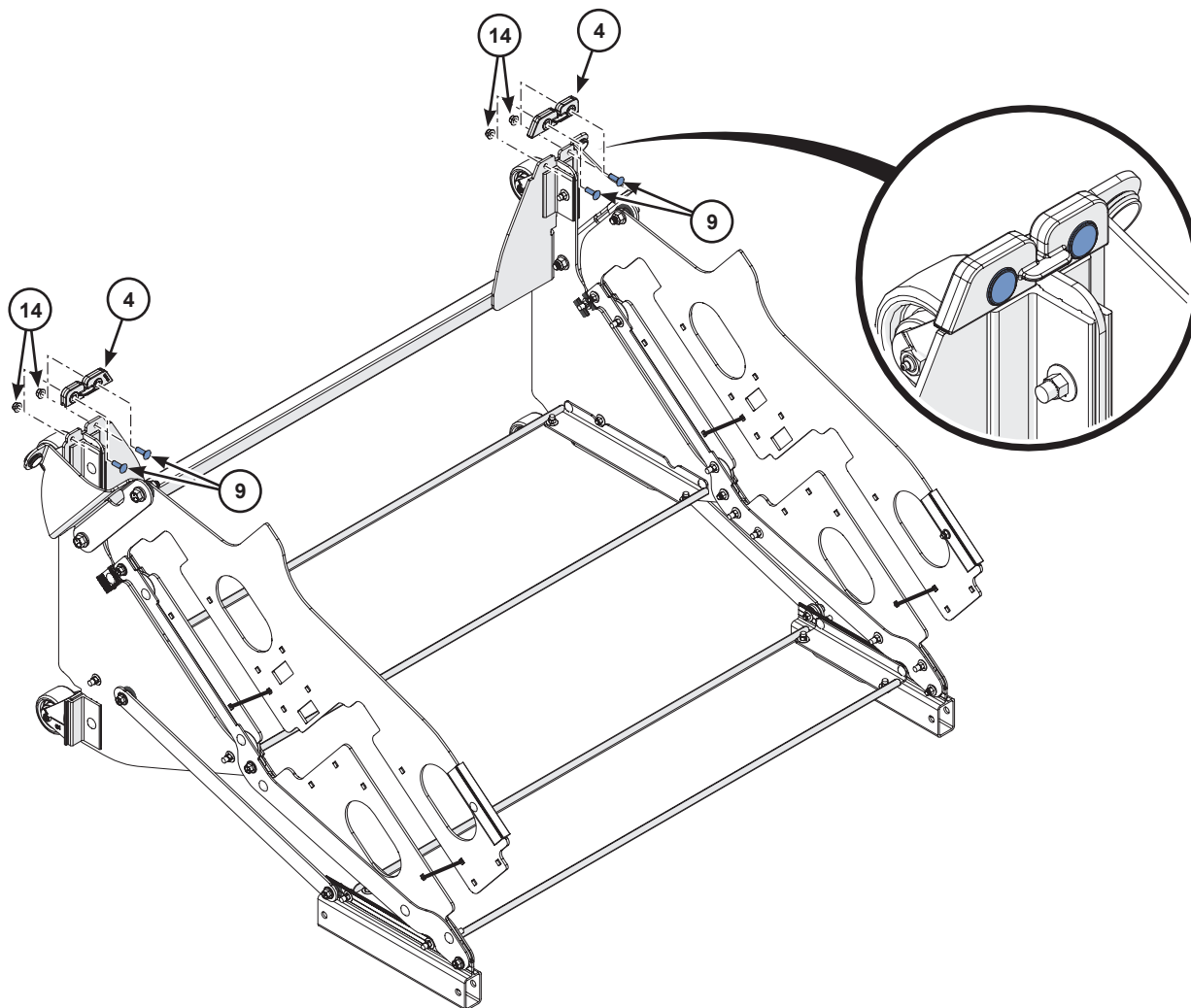

Assembly (continued)

8. Tip the riser onto the casters.
9. Pinch and push the snap-in glides (5) into the top and bottom of the rear channel of both side frames. The button on both sides should snap through the holes.

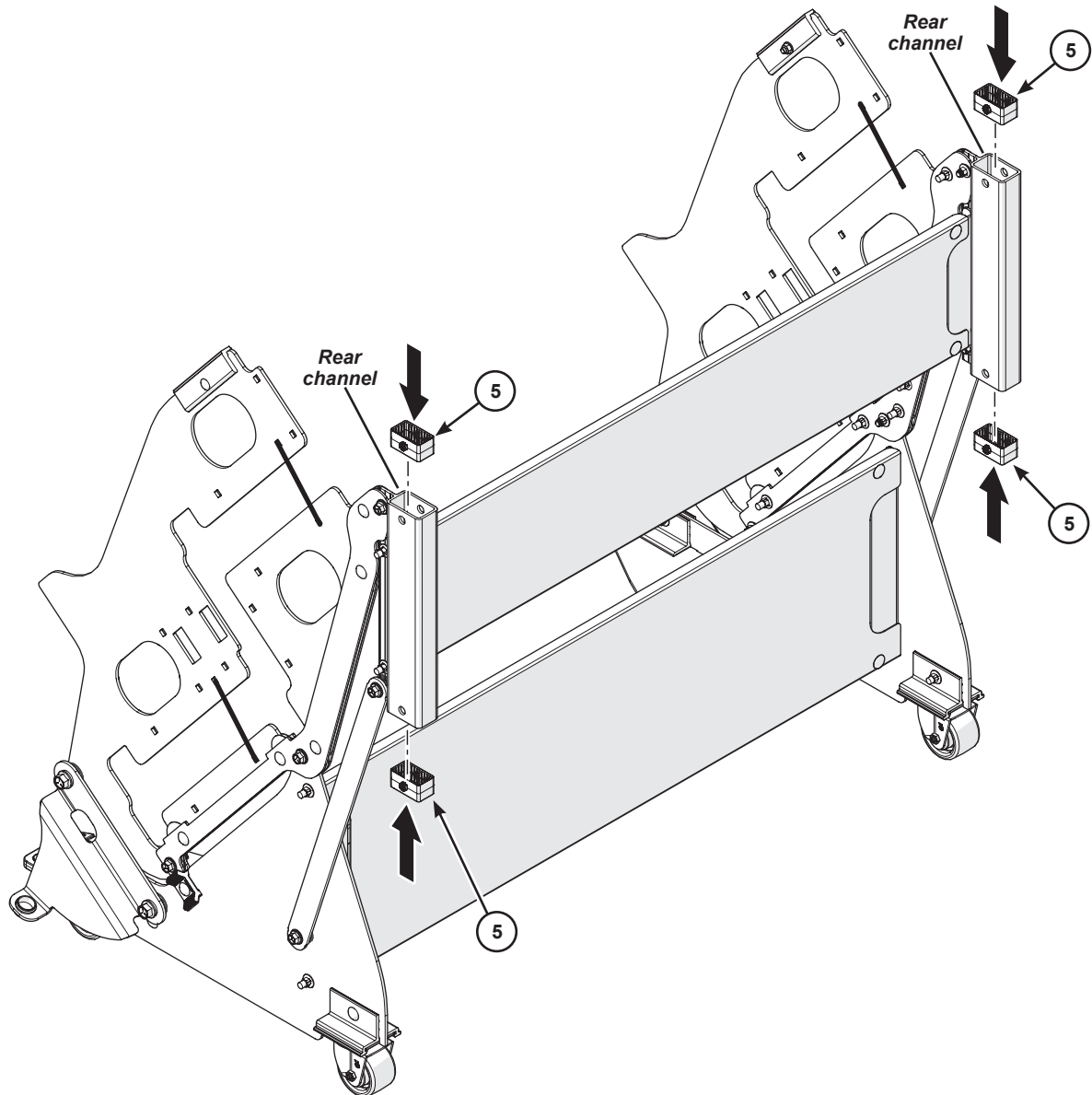

Assembly (continued)

10. With the pilot hole end toward the top, carefully slide the backrail upright tubes (29) through the rear channel of both side frames.

CAUTION

Lower the backrail upright tubes to the floor, do not drop them. Damage can occur.

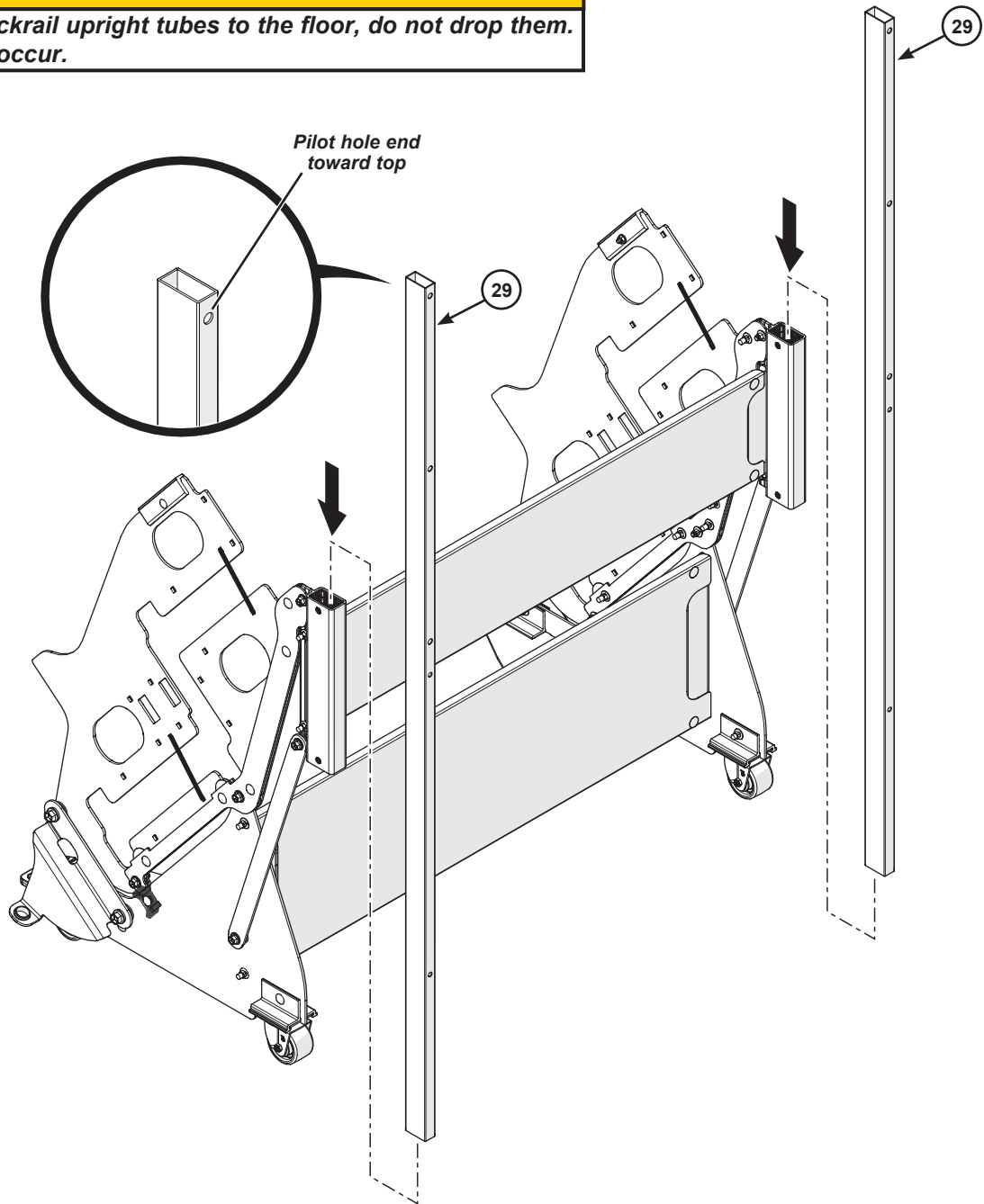

Assembly (continued)

11. Attach a backrail stop block (6) to the bottom hole of both upright tubes using one 3/8-16 x 3" carriage bolt (8) and 3/8-16 flange lock nut (13) in each.

This step uses fasteners:

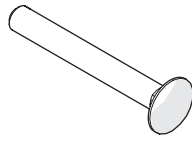

3/8-16 x 3"
Carriage Bolt (8)



3/8-16
Flange Lock Nut (13)

⚠ WARNING

Riser will not function properly without the stop blocks installed.

Failure to install the stop blocks will void the product warranty.

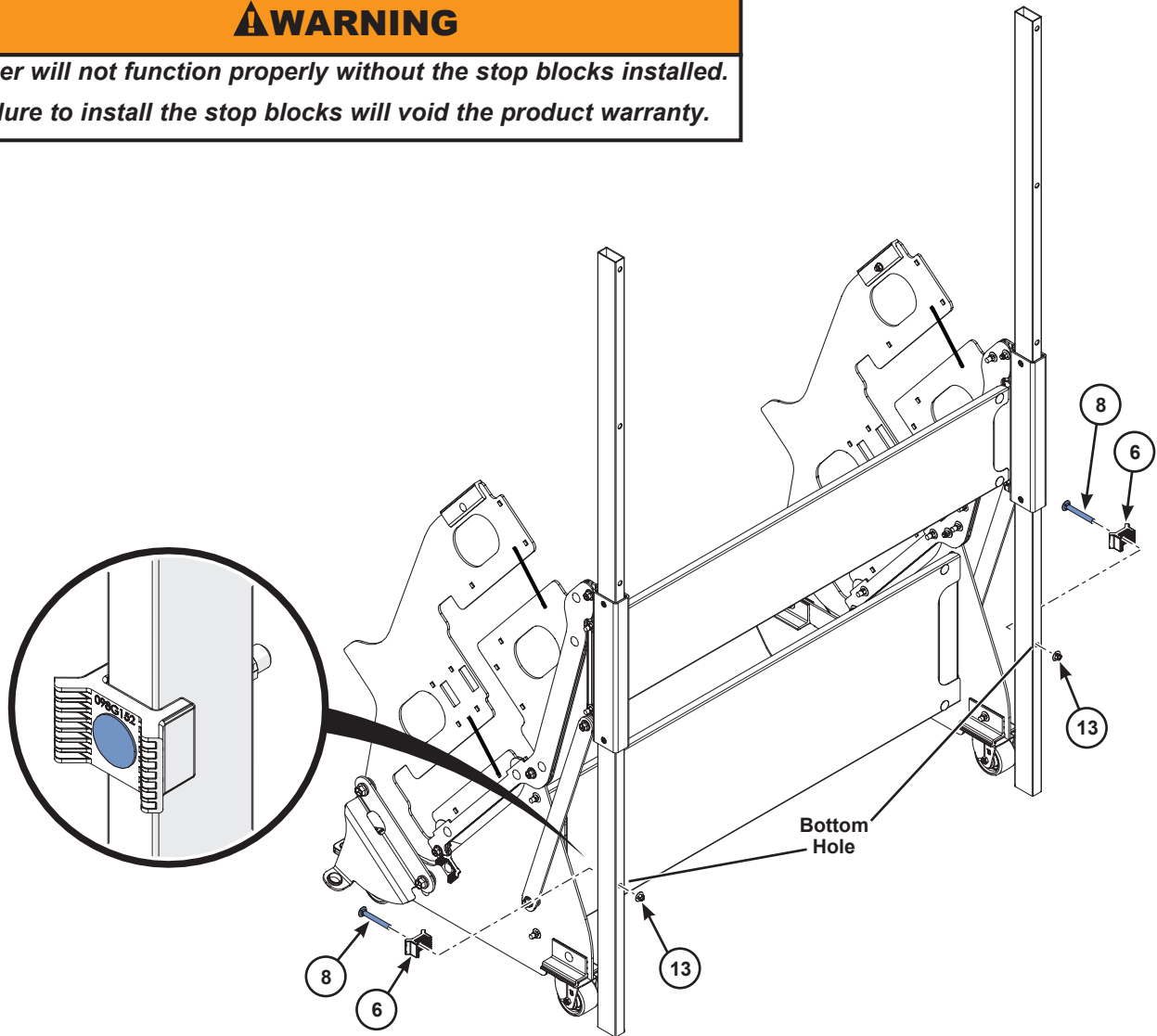

Assembly (continued)

12. Push one 1" x 2" cap (3) onto the bottom of both upright tubes.
13. Push one 1" x 2" plug (7) into the top of both upright tubes.

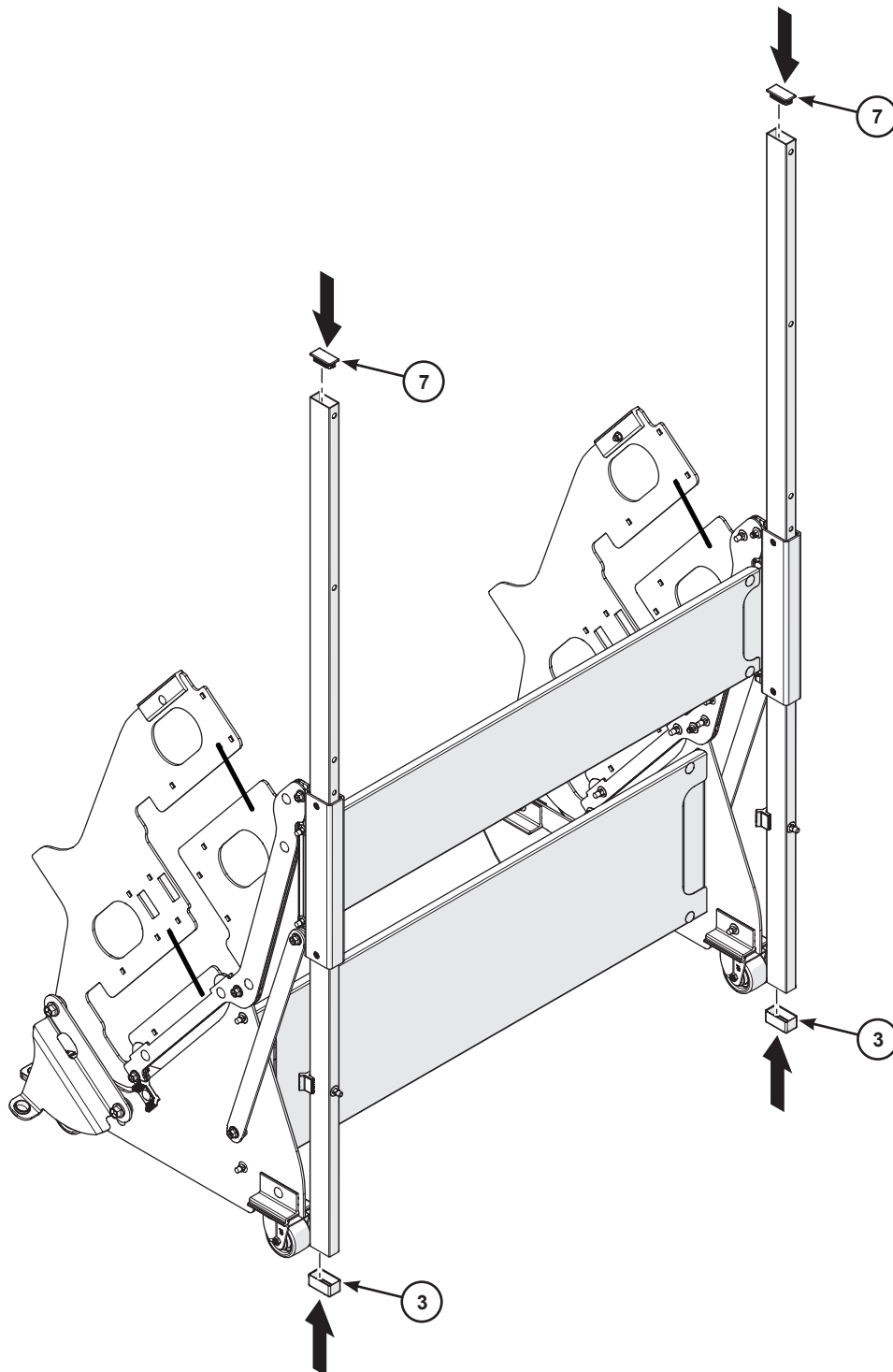

Assembly (continued)



This step shows the backrail horizontal tubes being installed for the standard assembly risers only. For reversed assembly risers, see "Reversed Riser Assembly" on page 29.

14. Attach the backrail horizontal tubes to the upright tubes.
 - a. Remove and discard the protective rubber caps from the threaded studs of the backrail horizontal tubes (30).
 - b. Insert the treaded studs of the horizontal tubes through the top three sets of holes in the upright tubes.
 - c. Secure each horizontal tube using two 3/8-16 jam lock nuts (12).

This step uses fasteners:



3/8-16
Jam Lock Nut (12)

⚠ WARNING

The backrail assembly must remain attached at all times.

Removal will cause riser instability and could result in injury.

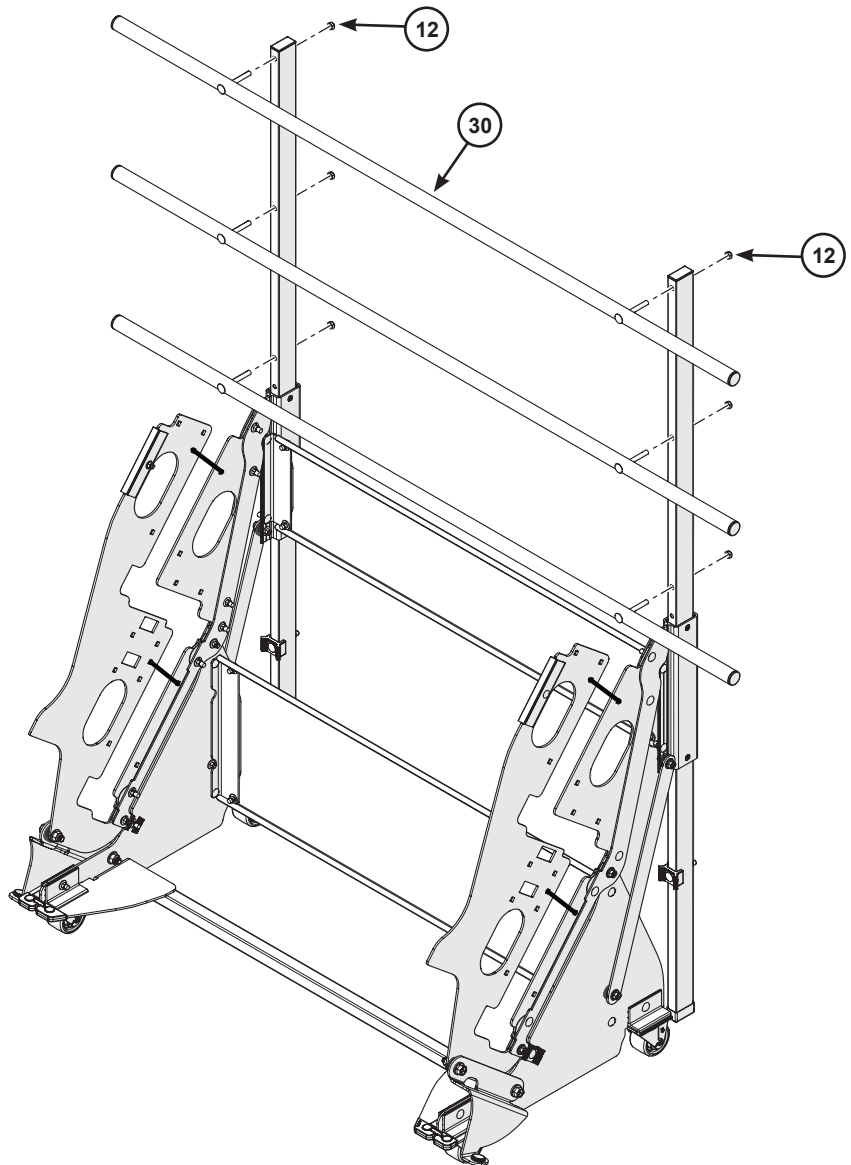

Assembly (continued)

15. While **firmly** holding on to the side frame assemblies, remove the remaining plastic bands that keep them closed.

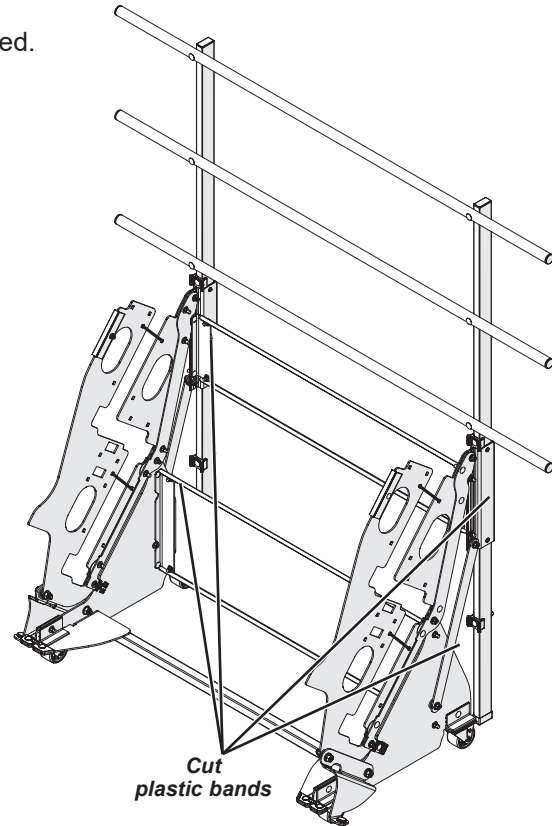

16. With one person at each side frame assembly, carefully fold them both down both at the same time until they touch the floor.

CAUTION

Lower the side frame assemblies to the floor, do not drop them. Damage can occur.

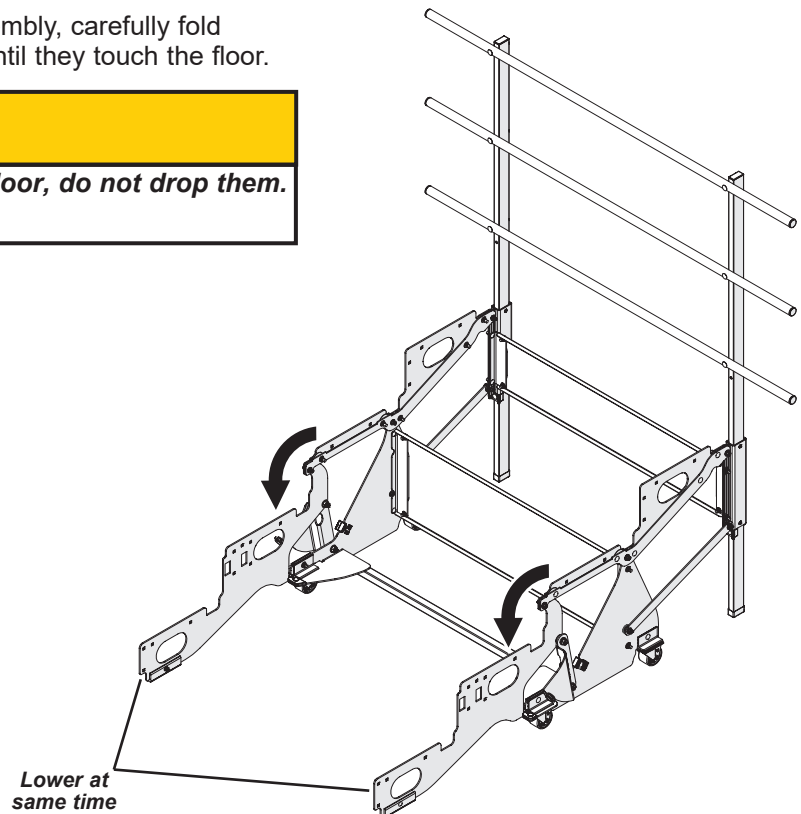

Assembly (continued)

STOP If an optional siderail will be attached to the riser, stop here and refer to the instructions included with the siderail kit.

17. With the U-channel at the bottom, attach the three small truss pans (28) to the side frames using two 3/8-16 x 1" carriage bolts (11) and 3/8-16 flange lock nuts (13) on each side.

On second step only:

For standard assembly risers use the front set of holes.

For reversed assembly risers use the rear set of holes to accommodate the siderail kit.

This step uses fasteners:



3/8-16 x 1"
Carriage Bolt (11)



3/8-16
Flange Lock Nut (13)

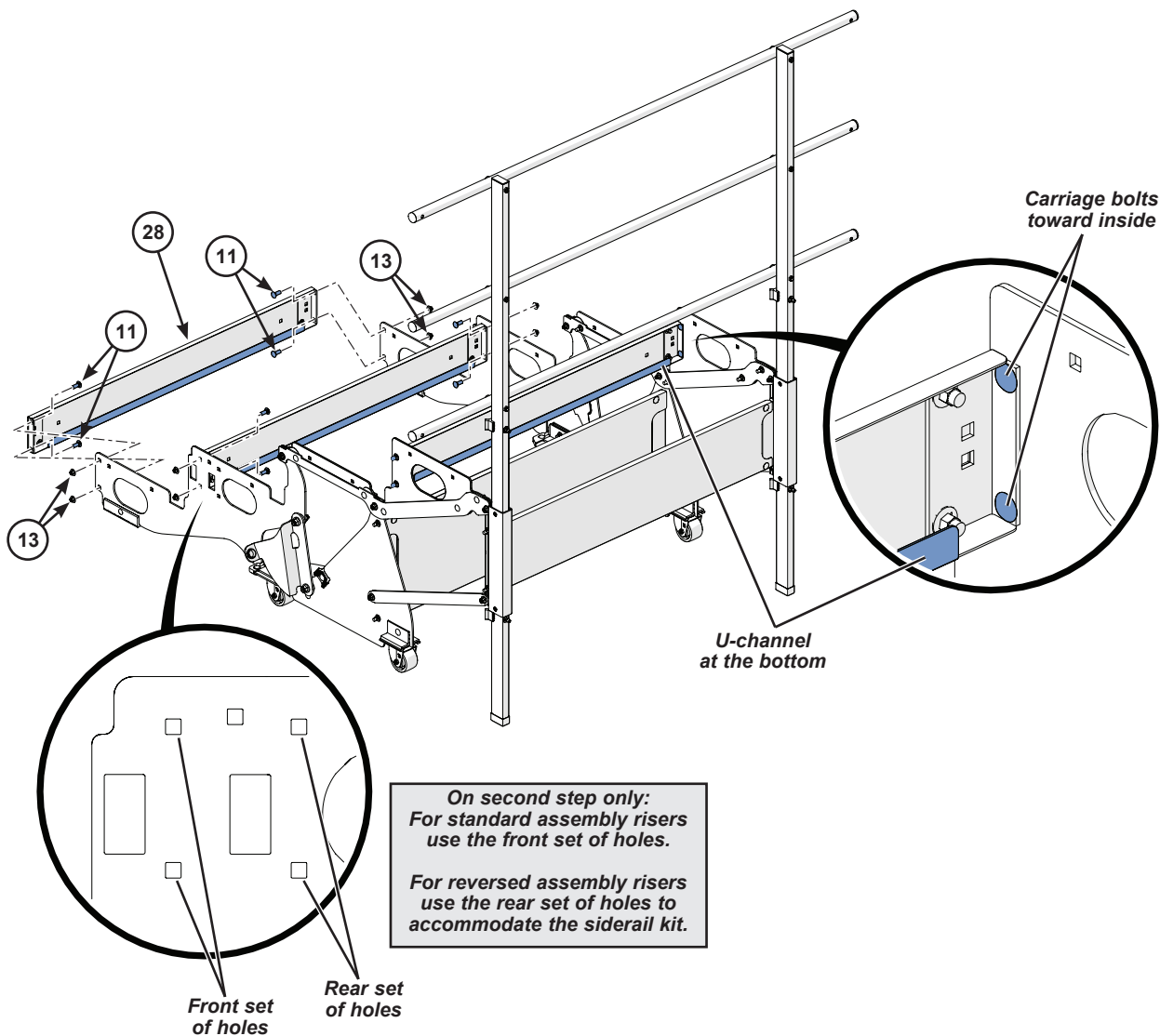

Assembly (continued)

18. Attach a backrail stop block (6) to the remaining hole in both upright tubes using one 3/8-16 x 3" carriage bolt (8) and 3/8-16 flange lock nut (13) in each.

This step uses fasteners:

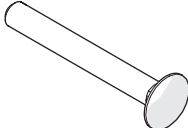

3/8-16 x 3"
Carriage Bolt (8)



3/8-16
Flange Lock Nut (13)

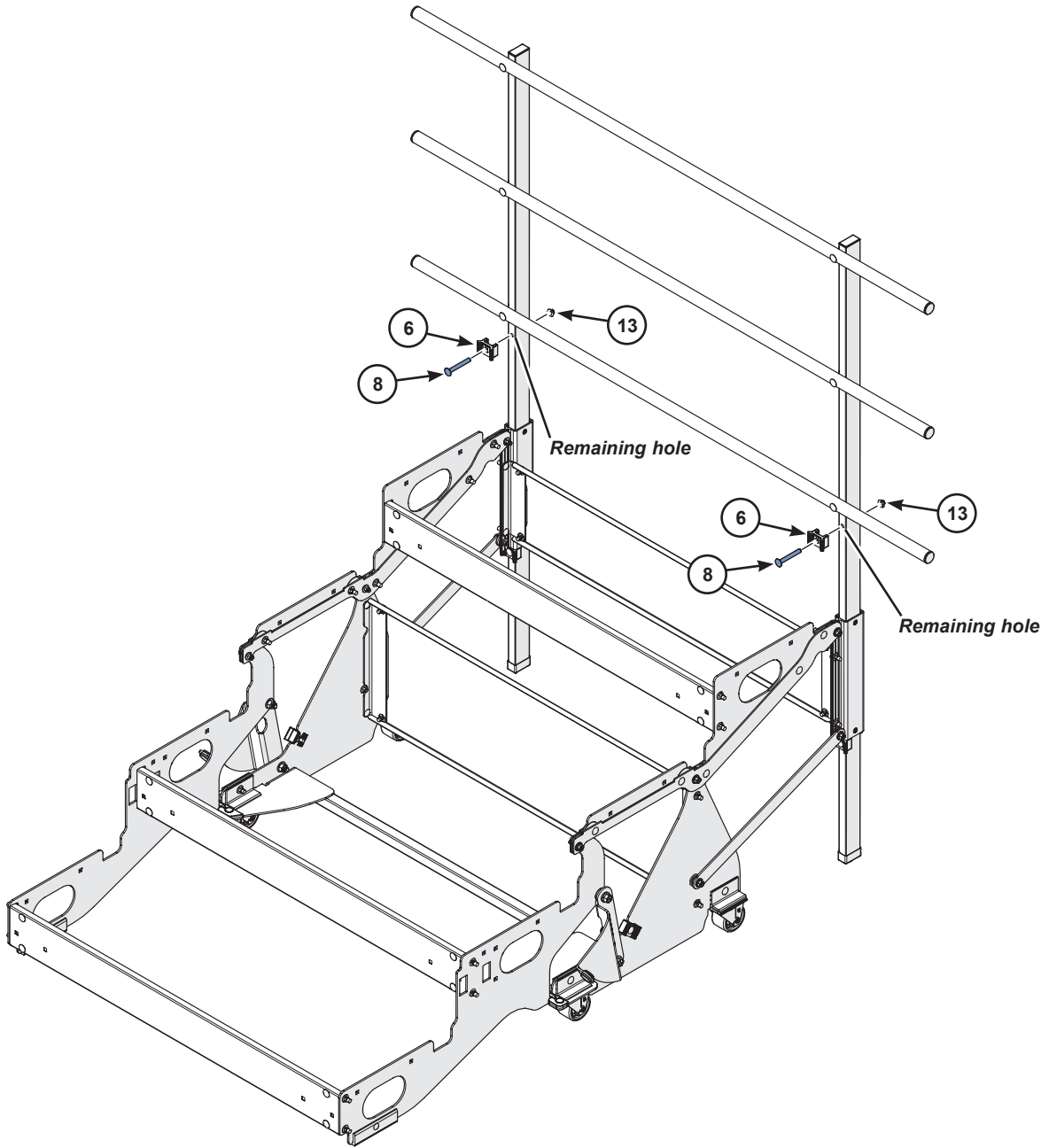

Assembly (continued)



This step shows the steps being installed for the standard assembly risers only.
For reversed assembly risers, see "Reversed Riser Assembly" on page 29.

19. Attach the steps to the side frames.

- Start with the longest step at the top and place them onto the side frames in descending order with the widest end at the rear as shown.
- Loosely attach all of the steps to the side frame** using two 3/8-16 x 1" carriage bolts (11) and 3/8-16 flange lock nuts (13) on each side.
- Fully tighten the nuts and bolts on the top two steps only.**

This step uses fasteners:



3/8-16 x 1"
Carriage Bolt (11)



3/8-16
Flange Lock Nut (13)

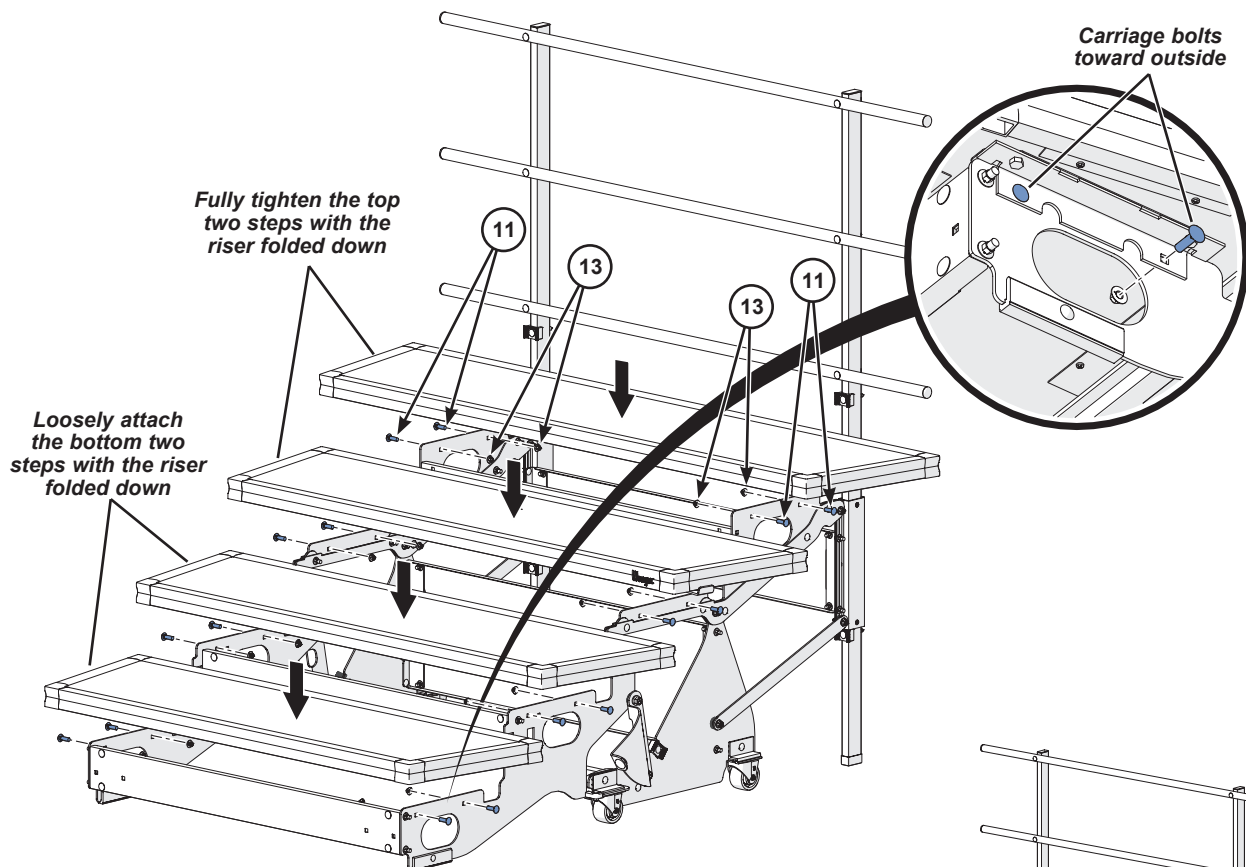

- Fold the riser into the Storage Position (see "Moving and Storage" on page 27) and fully tighten the fasteners on the bottom two steps.

CAUTION

Do not fold the side frames up until all of the steps have been attached with nuts and bolts.

Fully tighten the bottom two steps with the riser folded up

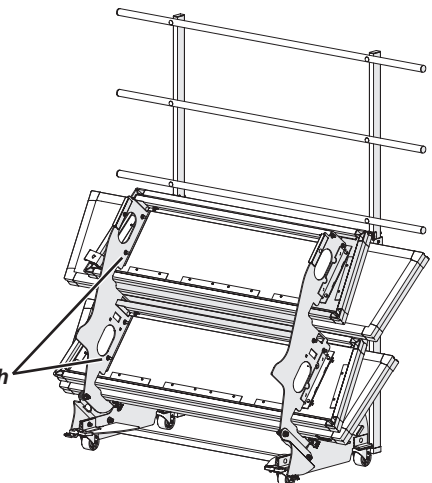

Safety Check

Before each use, with the riser in the Performance Position check the components for tightness and condition:

- a. All nuts and bolts on the chassis
- b. Backrail upright tubes
- c. Backrail horizontal tubes
- d. Steps

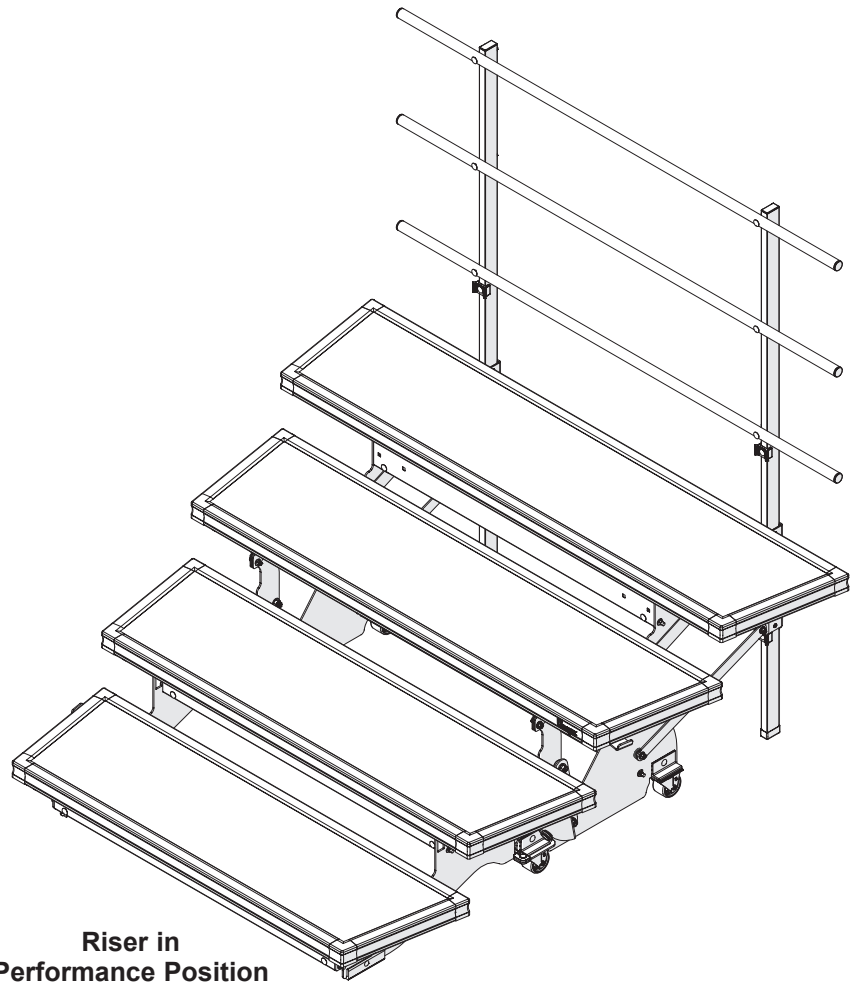

Moving and Storage

The riser must be put into the Storage Position to be moved and stored.

To place the riser in the Storage Position:

1. Lift up on the first step and fold it up to the backrail.

Wenger Corporation recommends using two people to lift and fold!

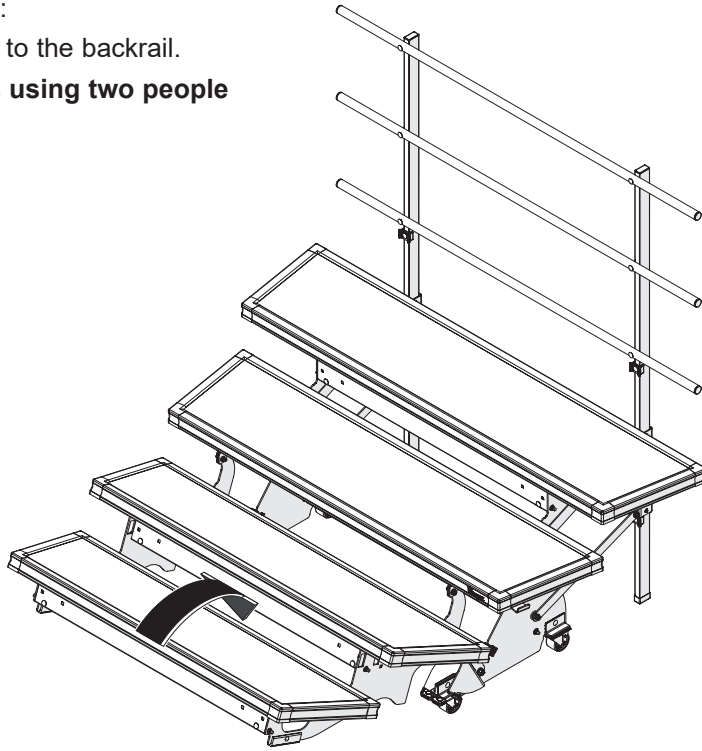

2. The riser can now be moved and stored.
3. To place the riser in the Performance Position, lower the first step to the ground.

CAUTION

Set up and use the riser only on flat, solid surfaces.

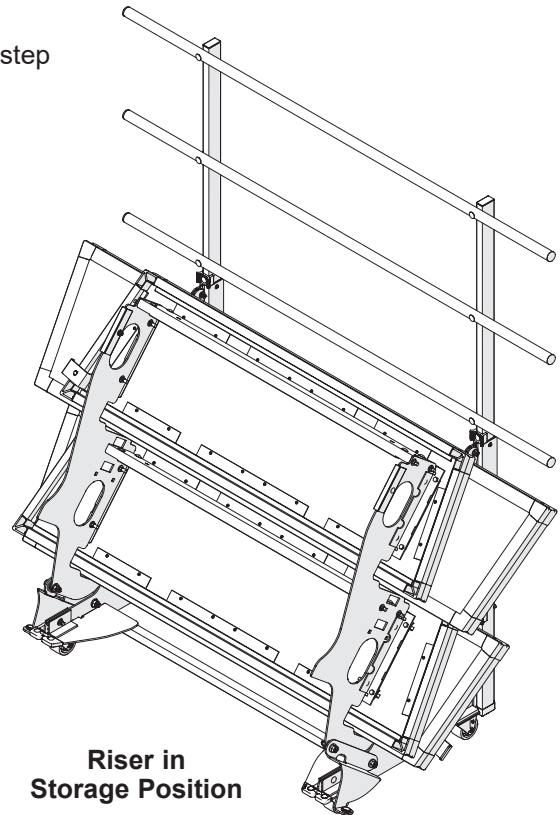

Connecting Riser Units

Risers can be connected to additional units using the unit connector brackets installed on the steps.

To connect risers together:

1. Roll an additional riser to be aligned as close as possible with the riser already placed in the Performance Position.
2. Unfold the riser into the Performance Position, setting the rear step onto the rear bracket of the already placed riser.
3. Lift the front step of the already placed riser over the front bracket of the additional riser.
4. If necessary, shift the positioning of the connected risers to fit tightly together.

⚠ WARNING

Adjoining risers can separate during use unless they are connected using the attached unit connector brackets.

⚠ CAUTION

Unused unit connector brackets can cause injury.

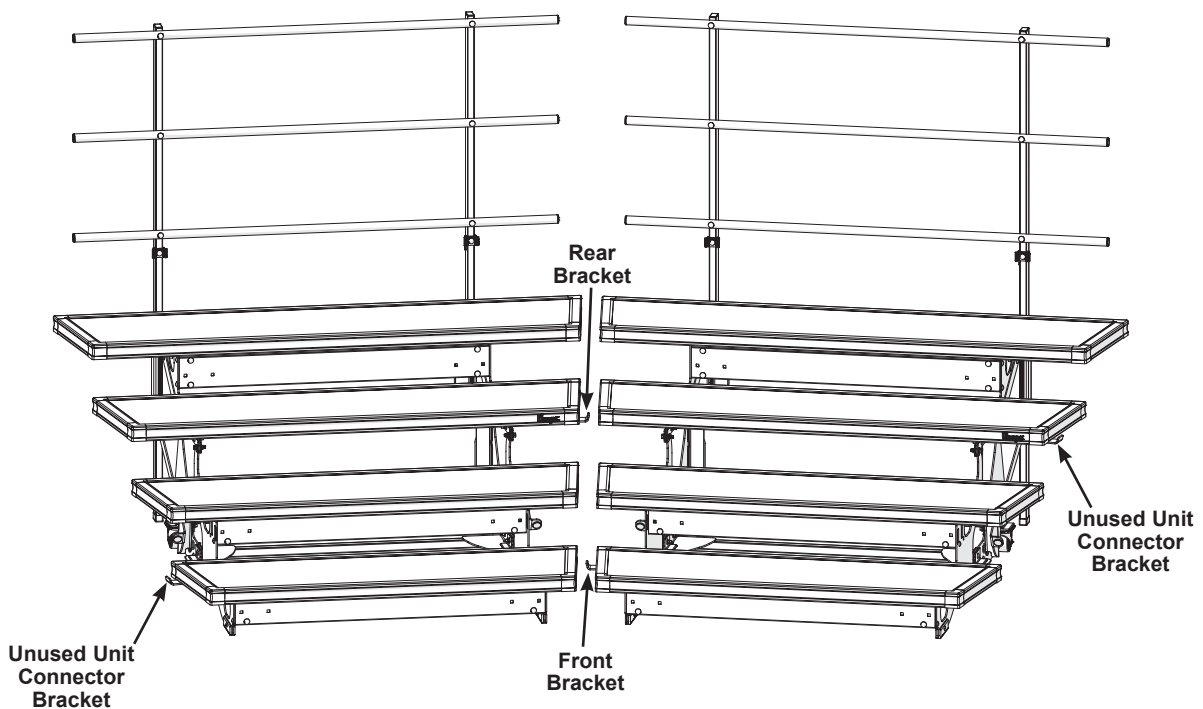

Reversed Riser Assembly



This section shows the steps and backrail horizontal tubes being installed for a reversed assembly riser.

The previous assembly instructions were for standard assembly risers.

To arrange risers in a straight configuration, alternating risers in the configuration must have the positioning of the steps and the backrail horizontal tubes reversed.

1. Fold the riser into the Storage Position and loosen but do not remove the nuts and bolts from the underside of the bottom two steps.

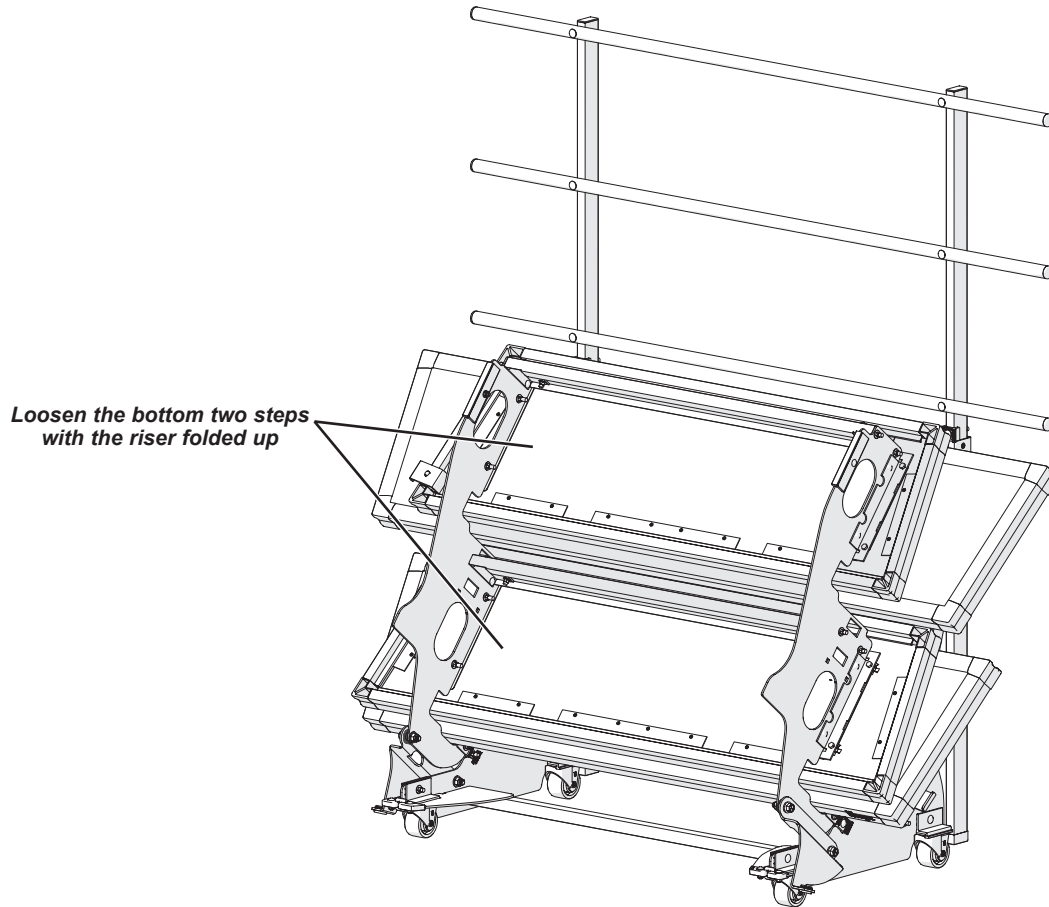

Reversed Riser Assembly (continued)

2. Fold the riser into the Performance Position and remove the nuts and bolts from the underside of all steps.

CAUTION

Do not fold the side frames up until all of the steps have been attached with nuts and bolts.

3. Reverse the backrail horizontal tubes.

- a. Fold the riser into the Performance Position and remove the backrail horizontal tubes by removing the lock nuts on the rear side of the upright tubes.
- b. Reattach the horizontal tubes to the rear side of the upright tubes and secure them with the lock nuts from the front side.

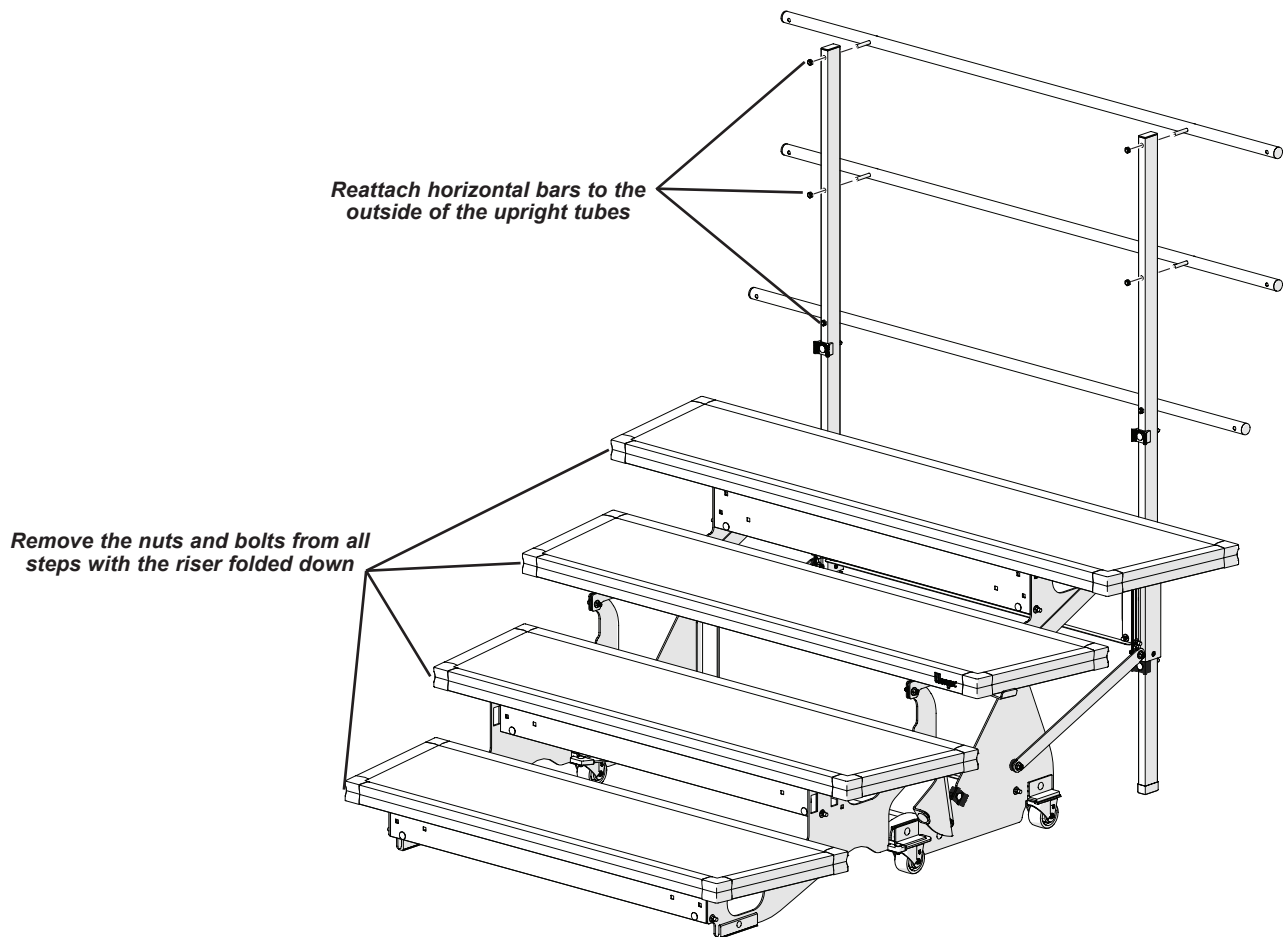

Reversed Riser Assembly (continued)



If an optional siderail will be attached to the riser, stop here and follow step 4 (also see page 23) before proceeding.

- The small truss pan on the second step may need to be moved.

On second step only:

for standard assembly risers use the front set of holes.

For reversed assembly risers use the rear set of holes to accommodate the siderail kit.

- Remove each step and rotate them 180°. Use the same nuts and bolts to loosely reattach the rotated steps in reverse order with the **longest step at the front and the shortest step at the rear**.
- Only fully tighten the nuts and bolts on the top two steps.

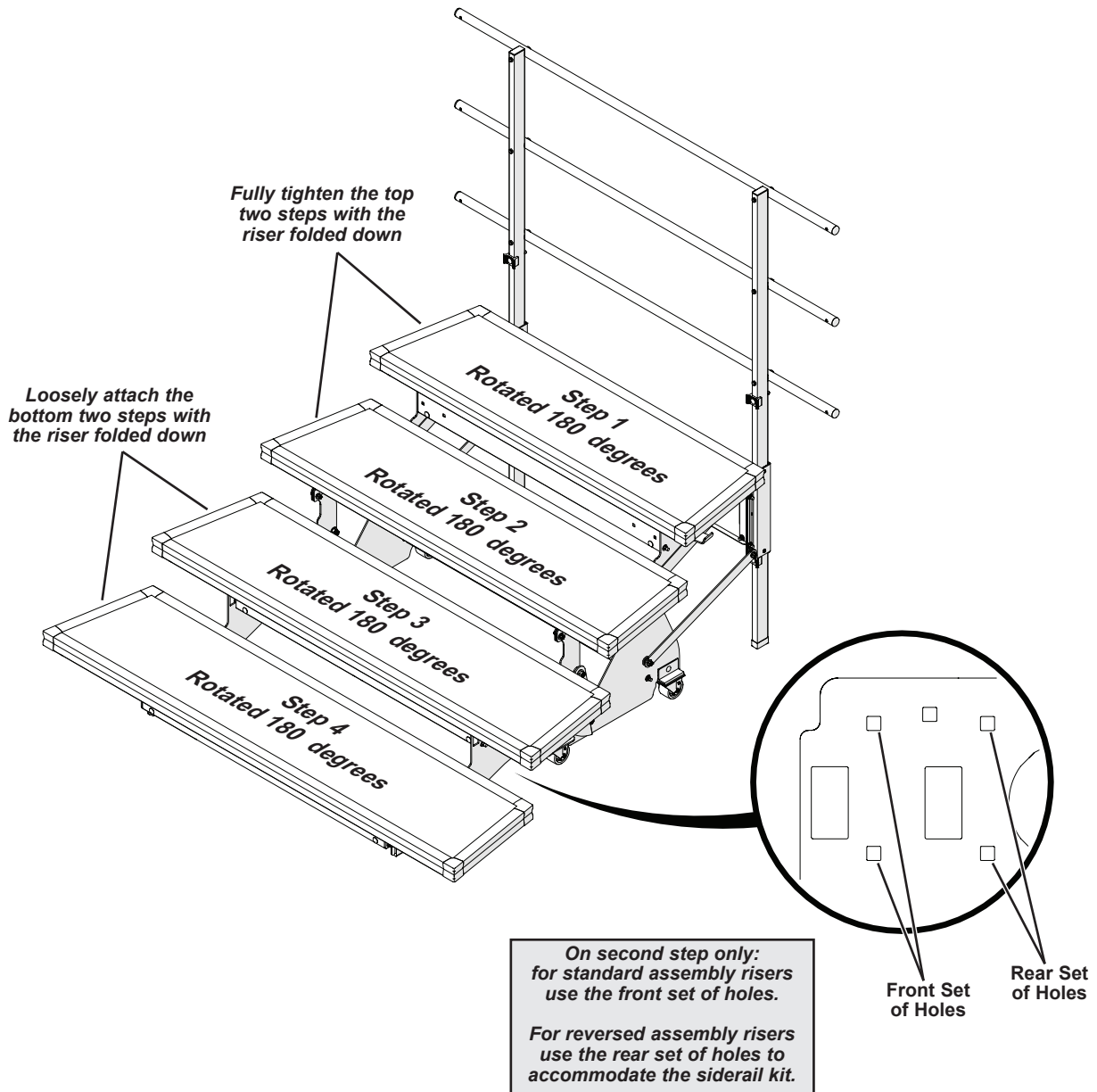

Reversed Riser Assembly (continued)

7. Fold the riser into the Storage Position and fully tighten the fasteners on the bottom two steps.

